



BACKHOE LOADERS | 3CX COMPACT RANGE

Gross power: 55kW (74hp) | Maximum dig depth: 4.33m | Weight: 6070kg



Introducing the 3CX Compact range.

Back in 1953, JCB introduced the market to one of the world's most pioneering machines, the 'Backhoe Loader'. This provided our customers with a versatile 3 in 1 machine that changed working practice and increased productivity.

With the world becoming more populated, buildings being built closer together and more infrastructure being required, the Backhoe Loader plays a key role in this development.

The 3CX Compact was launched in 2015, providing the market with a machine which was more compact than a standard backhoe yet offered the same capability on or off road as its larger sibling.

Now the 3CX Compact is evolving again, with the addition of two new models – **PLUS** & **PRO**, which will provide our customers with increased versatility through new transmission features, hydraulic systems, attachment capability and much more...

Making the 3CX Compact, the ultimate Tool Carrier in the market.

3CX COMPACT.

The 3CX Compact is our entry level machine, providing a high performing backhoe loader in a compact package.

The following features are fitted as standard:

40kph transmission, piston pump hydraulics and servo excavator controls make this the ideal machine for where a larger backhoe cannot access.



Power	55kW		
Travel speed	40kph		
Transmission	HydroStatic		
Loader lever	Twin lever		
Front auxiliary flow	70 lpm		
Excavator	10' Fixed	10' Extending	12' Extending

3CX COMPACT PLUS.

The **3CX Compact PLUS** is our new, mid range machine offering, with all the same features as the entry level machine plus new added features fitted as standard:

Vari Speed – provides the operator with the ability to set a constant speed.

- 70 lpm Constant Flow – allows the flow of the attachment to be set to a desired setting, such as a sweeper collector.
- Single loader lever with proportional auxiliary control – gives the customer precision control over the attachment fitted.
- Front Quickhitch options – Either a Mk2 BHL front coupler or a skid steer loader coupler which increases the amount of front end attachments that can be fitted for added versatility.



Power	55kW			
Travel speed	40kph			
Transmission	HydroStatic + Vari Speed			
Loader lever	Single lever			
Front auxiliary flow	70lpm + Constant flow			
Excavator	10' Fixed	10' Extending	12' Fixed	12' Extending

3CX COMPACT PRO.

The **3CX Compact PRO** is the flagship offering in our range and the introduction of true SSL capability will open up its potential to many new sectors.

With all the standard features plus others that have been greatly enhanced, this is the ideal machine for where a larger backhoe cannot access.

• Vari Speed PRO – provides the operator with the ability to preselect a preferred forward speed and keep constant while driving on different terrain.

• 7 Way Multifunction lever – Provides better control of the machine.

• Hi Flow – Standard up to 120 lpm allows the use of more powerful attachments.



Power	55kW	
Travel speed	40kph	
Transmission	HydroStatic + Vari Speed PRO	
Loader lever	7 Way multifunction	
Front auxiliary flow	120 lpm + Constant flow	
Excavator	10' Extending	12' Extending

MORE COMPACT.

SPACE IS BECOMING A PREMIUM. THAT'S WHY THE 3CX COMPACT RANGE HAS BEEN DESIGNED TO GIVE YOU PERFORMANCE IN A SMALL AREA. THIS MAKES IT PERFECT FOR URBAN WORKING AND RESTRICTED CONSTRUCTION SITES.



1 35% smaller than a standard BHL.

2 2m wide and 2.74m high – 50cm narrower than a standard backhoe, 25% lower than a standard 3CX.

3 Narrow width lets you, enter parks and small construction sites with restricted access.

4 Low working height unlocks a new range of previously inaccessible work sites, such as low level buildings and basements.

6m turning circle and 2m width means it can work in a single carriageway allowing a road to be kept open.

1

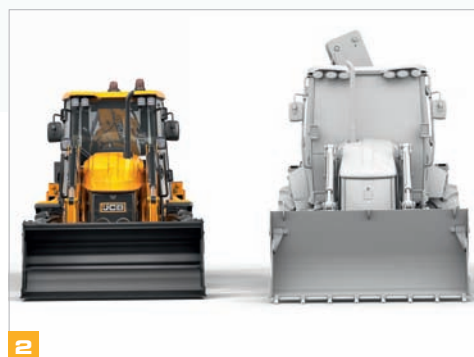

2



3



4

35% smaller than
a standard
backhoe.



MORE MOBILITY & MANOEUVRABILITY.

THE 3CX COMPACT IS THE ULTIMATE IN MANOEUVRABILITY. ITS TIGHT TURNING CIRCLE AND SWITCHABLE STEERING MODES ALLOW IT TO WORK IN A SINGLE CARRIAGEWAY WITH MINIMUM DISRUPTION AND MAXIMUM PRODUCTIVITY.

1 Auto switchable 2WS/4WS allows the operator to change between roading mode to site with ease (PRO only).

2 A three speed 40 kph hydrostatic transmission makes the 3CX Compact an incredibly independent machine with a large working radius for optimum productivity, without the reliance on other equipment for transport.

3 The 3CX Compact is powered by a high torque 55kW (74hp) JCB by Kohler engine that requires no after treatment, keeping servicing costs and downtime to a minimum.

4 Vari Speed transmission is standard on the **PLUS** machine, which allows operators to preselect a preferred forward speed, a benefit when using attachments like sweeper brushes and collectors.

4 Vari Speed PRO transmission, standard on the **PRO** allows operators to preselect a preferred forward speed and keep constant while driving on different terrain, a benefit when using attachments like trenchers and cold planers.

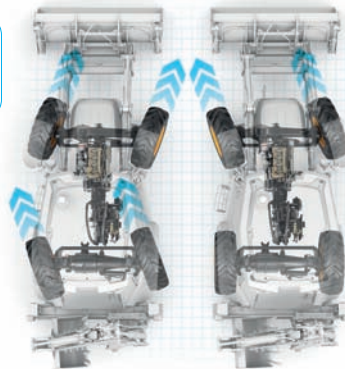

1

Four-wheel steer

Two-wheel steer



2

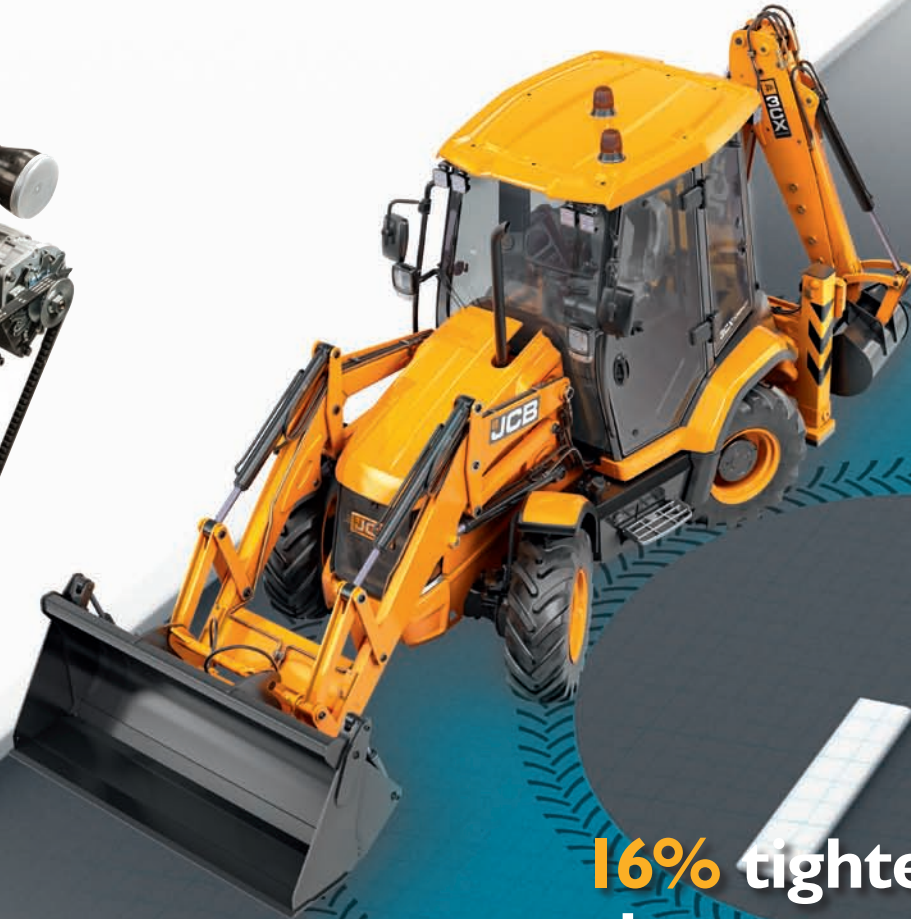

An impressive 5.8 metre turning circle (with applied brakes) allows the machine to turn a full 180 degrees in a single carriageway.

16% tighter turning circle than a standard backhoe.



MORE COMFORT.

A SPACIOUS CAB WITH EXCAVATOR CONTROLS PROVIDES OPTIMUM EASE OF USE AND CONTROLLABILITY. THIS ALSO HELPS TO IMPROVE THE OPERATOR'S SEATING POSITION, WHICH IN TURN MAKES IT A LOT MORE COMFORTABLE.

1 Excavator style controls fitted as standard for ease of use and controllability.

2 SmoothRide System increases operator comfort on and off-road, as well as improving load retention.

3 Powerslide option enables effortless repositioning of the boom, maximising operator ease of use and saving time and unnecessary damage to the street. It also allows uncompromised visibility to the ground and the attachment, for maximum precision and improved safety.

4 Plenty of internal/external storage space in the 3CX Compact helps organise the cab environment for improved comfort levels.

5 12V auxiliary circuit – For powering of useful accessories such as phone chargers.

6 Twin control lever – **Compact**

7 Single control lever – **Compact PLUS**

8 7-way multifunction lever – **Compact PRO**



3CX Compact cab.



MORE VERSATILE.

THE 3CX COMPACT IS NOT ONLY DESIGNED FOR THE VAST RANGE OF BACKHOE LOADER ATTACHMENTS. WITH THE ADDITION OF THE 3CX COMPACT PLUS AND 3CX COMPACT PRO, IT ALSO HAS THE ABILITY TO PICK UP A WIDER RANGE OF HIGH POWERED SKID STEER LOADER ATTACHMENTS.



A 3-in-1 machine, the 3CX Compact can be a compact excavator and wheel loader, with skid steer attachment versatility.



The **versatile** one machine solution.



1 The 3CX Compact is not only designed for the vast range of tool carrier attachments. It also has the ability to pick up a wide range of skid steer loader attachments. Bi-directional pipework and a handheld tool circuit provide even greater versatility.

2 With 120lpm auxiliary flow, attachments such as trenchers can now be used .

3 This one machine can tackle multiple jobs eg. Pumping water, hand breakers, power tools, disc breakers.



MORE SAFE & SECURE.

THE 3CX COMPACT COMES STANDARD WITH MANY NEW AND IMPROVED SAFETY FEATURES TO KEEP THE OPERATOR SAFER THAN EVER BEFORE. OPTIONAL FEATURES ALSO AVAILABLE INCLUDE DUST SUPPRESSION, FISH EYE MIRRORS AND LED LIGHTS AND BEACONS.

1 Immobilisers – Protect the machine. Simply programme a numerical keycode to prevent unauthorised use.



2 Optional Fish Eye mirror – provides full visibility to all rear attachments and blindspots.

Door sensor – Isolates auxiliary constant flow to prevent unauthorised operation of attachments.

3 Ground level daily checks, make greasing safer with easier machine servicing. There is also a large, ground level capacity fuel tank for safe refuelling.



4 Good 360° operator visibility from the cab, ensures the operator remains in control of the working area.





5 LED beacon and LED work lights provide clear vision during all hours of the day.

6 Step light provides greater visibility clear vision when accessing the cab during night hours.

7 Twin anti slip steps with an open grille design prevents build up of material for safe entry/exit to machine.

8 JCB's LiveLink telematics system allows you to monitor and manage your machine remotely anywhere in the world so you can improve the efficiency and security of your machine.

9 3 points of contact for greater operator safety when entering/exiting machine.



MORE OPTIONS.



LED worklights and beacons.

Provides clear vision during all hours of the day.



Tow hitch.

Optional tow hitch enables the machine to move items around site and tow its own attachments.



Tool boxes.

Lockable tool box External and internal for safe and secure storage of tools.



Front and rear camera.

Optional front and reversing camera provides additional visibility to the operator, essential when working in busy sites or where pedestrians are in close proximity.



Clam/Ram guards.

The rams are reliable because they are protected from debris when loading by optional JCB clam shovel ram guards.



Periscope mirror.

Provides clear visibility to all front end attachments.



Lifting kits.

Enable the machine to carry out lifting operations. Hose burst check valves and an audible warning alarm maximise site safety.



Fish eye.

Mirror provides full visibility to all rear attachments and blindspots.



Immobilisers.

Protects the machine. Programme a numerical keycode to prevent unauthorised use.



Hand held tool carrier.

Ability for one machine to tackle multiple jobs eg. Pumping water, hand breakers, power tools, disc breakers.



ISO/SAE.

Controls For ultimate customisation. Choose optional SAE+/ISO+ control panel switch.



Step Lights.

Clear visibility when accessing or exiting the cab during night hours.



Powerslide.

Effortless repositioning of the boom, maximising operator ease of use and saving time and unnecessary damage to the street. It also allows uncompromised visibility to the ground and the attachment for maximum precision and improved safety.

Rear quickhitch.

Rear mechanical quickhitch to easily switch between attachments for complete versatility on any job.

MORE TYRE OPTIONS.

JCB OFFER A WIDE RANGE OF TYRES TO SUIT A WIDE VARIETY OF INDUSTRIES AND APPLICATIONS. A CHOICE OF CROSS-PLY OR RADIAL AND TREAD TYPES, ENSURE THE 3CX COMPACT HAS THE RIGHT TYRE FOR THE RIGHT CONDITIONS.



Sitemaster.

The JCB Sitemaster is a cross-ply type construction and provides good performance, value and durability for the operator.

12.5-18-10



Michelin Power CL.

The cross-ply Power CL tyre provides strength and stability with a high resistance to impacts and punctures. The sidewall integrity gives excellent vertical and lateral stability.

340/80-18



Michelin XMCL.

The radial construction of the XMCL gives excellent traction in dry or wet and difficult conditions. This tyre provides great wear characteristics and exceptional comfort when out on the road.

340/80 R18



Michelin Bibload.

The Bibload tyre is a true hard surface tyre that resists wear and tear and improves ride quality for the operator. The strong sidewall construction reduces the risk of punctures and it has exceptional lateral stability for a radial tyre.

340/80 R18



Michelin XP27.

The XP27 tyre is ideal for reducing the impact on ground condition with the ability to work at lower pressures, making this tyre the ideal turf tyre. The tyre also provides a low rolling resistance which helps save fuel.

340/65 R18

3CX COMPACT.

AT 35% SMALLER THAN A STANDARD BACKHOE, THE 3CX COMPACT PROVIDES A VERSATILE SOLUTION FOR AREAS WHERE A LARGER MACHINE CANNOT ACCESS. IT IS LOWER IN HEIGHT AND NARROWER, HAS A TIGHTER TURNING CIRCLE PROVIDING EXCELLENT MANOEUVRABILITY AND HAS A 40KPH HYDROSTATIC TRANSMISSION, MEANING IT CAN TRAVEL TO SITE INDEPENDENTLY. IDEAL FOR A WIDE RANGE OF INDUSTRIES SUCH AS CONSTRUCTION, HIGHWAYS AND CIVILS.



Power	55kW		
Travel speed	40 kph		
Transmission	HydroStatic		
Loader lever	Twin lever		
Front auxiliary flow	120 lpm		
Excavator	10' fixed	10' extending	12' extending
GP	•		
Direct mount	•		
3/8 pipework	•		
Constant flow	•		
No pipework	•		
Twin loader lever	•		
Yellow roof with black rear fenders	•		



3CX COMPACT PLUS.

THE 3CX COMPACT PLUS HAS THE SAME ATTRIBUTES AS THE 3CX COMPACT, PLUS HYDRAULIC AUXILIARY TO THE LOADER. THIS PROVIDES CONSTANT FLOW AND VARI SPEED, MAKING IT IDEAL FOR WHERE ATTACHMENTS SUCH AS LO FLOW SWEEPER COLLECTORS OR TRENCHERS CAN BE USED. AN OPTIONAL SSL QUICK COUPLER FURTHER INCREASES VERSATILITY WITH A WIDE RANGE OF LO FLOW SSL ATTACHMENTS. IDEAL FOR LANDSCAPING, UTILITIES AND MUNICIPALITIES.



Power	55kW			
Travel speed	40 kph			
Transmission	HydroStatic + Vari Speed			
Loader lever	Single lever			
Front auxiliary flow	70 lpm + constant flow			
Excavator	10' fixed	10' extending	12' fixed	12' extending
GP	•			
Mk2 QH	•			
5/8 pipework	•			
Constant flow	•			
No pipework	•			
Single loader lever	•			
Yellow roof with yellow rear fenders	•			



3CX COMPACT PRO.

THE 3CX COMPACT PRO IS THE TOP OF THE 3CX COMPACT RANGE. IT HAS 120LPM LOADER AUXILIARY FLOW AND A SSL QUICK COUPLER AS STANDARD WHICH INCREASES THE AMOUNT OF ATTACHMENTS THAT CAN BE FITTED. ITS VARI SPEED PRO TRANSMISSION AND 7 WAY MULTIFUNCTION LEVER GIVE THE OPERATOR COMPLETE CONTROL WHEN USING HI FLOW ATTACHMENTS. IDEAL FOR HIGHWAYS, LANDSCAPING, UTILITIES, TELECOMS, SNOW CLEARING AND MUCH MORE.



Power	55kW
Travel speed	40 kph
Transmission	HydroStatic + Vari Speed PRO
Loader lever	7-way multifunction
Front auxiliary flow	120 lpm + constant flow
Excavator	10' extending 12' extending
GP	•
SSL QH	•
5/8 pipework	•
Constant flow	•
No pipework	•
7-way multi loader lever	•
Vari speed Plus/Pro	•
Yellow roof with yellow rear fenders and black chevrons	•
Auto 2WS/4WS	•



3CX HIGHWAYS MASTER.

THE HIGHWAYS MASTER IS SOLELY DEDICATED TO THE HIGHWAYS INDUSTRY. IT HAS THE SAME FEATURES AS THE 3CX COMPACT PRO WITH THE ADDITION OF INDUSTRY COLOURS, RED AND WHITE CHEVRONS, DUST SUPPRESSION, SAFETY E STOPS, FRONT AND REAR CAMERAS AND POWERSLIDE AS STANDARD, PROVIDING THE ULTIMATE SOLUTION FOR THIS CHALLENGING INDUSTRY.

Power	55kW
Travel speed	40 kph
Transmission	HydroStatic + Vari Speed Pro
Loader lever	7-way multifunction
Front auxiliary flow	120 lpm + constant flow
Excavator	10' fixed 10' extending 12' extending
GP	•
SSH QH	•
5/8 pipework	•
Constant flow	•
Hammer/BiDi	•
7-way multi loader lever	•
Vari speed Plus/Pro	•
White and black loader	•
Dust suppression	•
Powerslide	•
Hi-viz decals	•
Auto 2WS/4WS	•
LED	•



LIVELINK, WORK SMARTER.

JCB LIVELINK IS AN INNOVATIVE SOFTWARE SYSTEM THAT LETS YOU MONITOR AND MANAGE YOUR MACHINES REMOTELY – ONLINE, BY EMAIL OR BY MOBILE PHONE.

Productivity and cost benefits –

Machine location information can improve fleet efficiency and you may even enjoy reduced insurance costs courtesy of the added security that LiveLink brings.

** Note: Please consult your local dealer for LiveLink availability*

LIVE  LINK



Maintenance benefits – Accurate hours monitoring, maintenance history records, critical machine alerts and service alerts improve maintenance planning.

Security benefits – Real-time geofencing lets you set operating zones and curfew alerts that tell you when your machinery outside of pre-determined times. Location information helps you store machines safely.

VALUE ADDED.

JCB'S WORLDWIDE CUSTOMER SUPPORT IS FIRST CLASS. WHATEVER YOU NEED AND WHEREVER YOU ARE, WE'LL BE AVAILABLE QUICKLY AND EFFICIENTLY TO HELP MAKE SURE YOUR MACHINERY IS PERFORMING TO ITS FULL POTENTIAL.



1 Our Technical Support Service provides instant access to factory expertise, day or night, while our Finance and Insurance teams are always on hand to provide fast, flexible, competitive quotes.

JCB offers comprehensive extended warranties and service agreements, as well as service-only or repair and maintenance contracts. Irrespective of what you opt for, our Maintenance teams around the world charge competitive labour rates, and offer non-obligation quotations as well as fast, efficient insurance repair work.

Note: JCB LIVELINK and JCB extended warranty packages may not be available in your region, so please check with your local dealer.



2 The global network of JCB Parts Centres is another model of efficiency; with 18 regional bases, we can deliver around 95% of all parts anywhere in the world within 24 hours. Our genuine JCB parts are designed to work in perfect harmony with your machine for optimum performance and productivity.

STATIC DIMENSIONS

Max. Engine power: 55kW (74hp) max. tool carrier dig depth: 4.33m

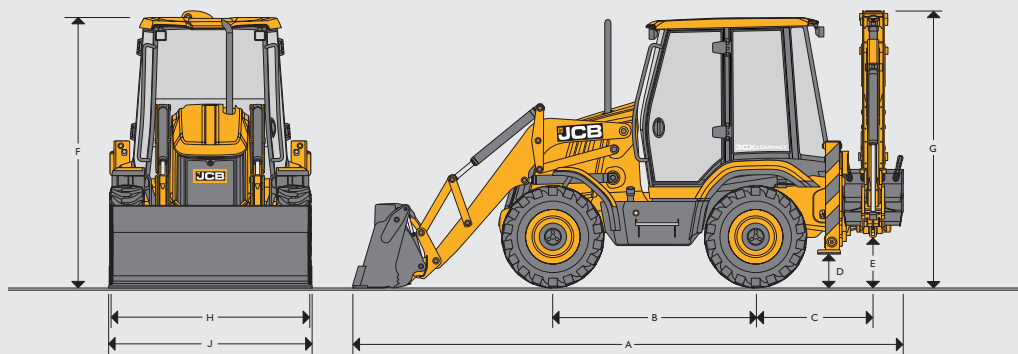

	3CX COMPACT	
A Total travel length	m	5.52
B Axle centreline distance	m	1.99
C Slew centre to rear axle centre distance	m	1.16
D Stabiliser feet clearance	m	0.33
E Kingpost clearance	m	0.52
F Cab roof height	m	2.65
G Total travel clearance (1.0ft)	m	2.74
Total travel clearance (1.2ft)	m	3.08
H Rear frame width	m	1.89
J Shovel width	m	2.01

JCB tool carriers feature heavy-duty one piece mainframe, hydrostatic driveline and fully enclosed engine compartment. All fluid and component compartments are lockable using the ignition key

GROUND LINE ANGLES

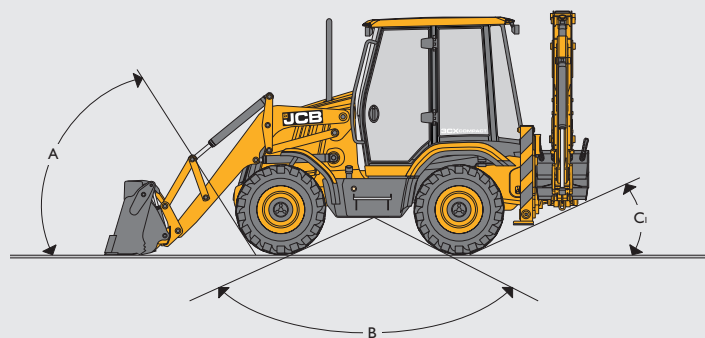

A Approach angle	degrees	45°
B Interference angle/ramp to ground plane	degrees	124.5°
C Departure angle	degrees	19°

ENGINE

Common rail diesel. Belt driven water pump. Cold start aid – territory dependent. Single side servicing.

Engine emissions		Stage IIIB/T4
Manufacturer		JCB Diesel by Kohler Co.
Gross power	kW (hp)	55 (74) @ 2200rpm
Peak torque	Nm	300
Aspiration		Turbo charged
Displacement	CC	2482
No. of cylinders		4
Bore	mm	88
Stroke	mm	102
Rated engine	rpm	2350

TRANSMISSION

Bosch Rexroth transmission with anti-stall and high speed roading switch.

Type		Hydrostatic
Model		Rexroth A6VM – 3 speed
1st (low range)	kph (mph)	6 (3.7)
2nd (high range)	kph (mph)	10 (6.2)
3rd (high speed)	kph (mph)	40 (24.9)

SERVICE CAPACITIES

Cooling system	ltr	16
Fuel tank	ltr	80
Engine oil sump	ltr	11.2
Hydraulic system (including transmission)	ltr	104
Rear axle	ltr	9.0
Front drive axle	ltr	9.0

AXLES

	Front	Rear
Type	JCB Max-trac steer drive torque proportioning	
Axle ratings	kg	
Static load rating	7484	
Dynamic load rating	3765	
Oscillation angle	9.5°	–
Steering ram	Double acting	Double acting

STEERING

Steering axles	Front and rear
Steering turns – lock to lock	4
Turning circle:	m
Inner wheels braked	5.8
Inner wheels not braked	6.7

OPERATING WEIGHTS

10ft Extradig	kg	6070
---------------	----	------

Operating weight includes machine with 6-in-1 shovel, 600mm excavator bucket, extended dipper, full fuel tank and operator.
Actual weight will vary depending on machine options.

NOISE AND VIBRATION LEVELS

Internal	dB(A)	71
External	dB(A)	101

LOADER DIMENSIONS

	G.P. Shovel	6-in-1 shovel	Narrow G.P. shovel
	m	m	m
Overall width with bucket	2.01	2.01	1.40
M Dump height	2.17	2.35	2.38
N Load over height	2.96	3.02	2.99
O Loader hinge pin height	3.20	3.20	3.20
P Pin forward reach	0.43	0.43	0.30
Q Reach at ground (toe plate horizontal)	1.52	1.52	1.58
R Max. reach at full height	1.16	1.16	1.22
S Reach at full height fully dumped	0.64	0.79	0.82
T Dig depth	0.15*	0.15*	0.15*
U Roll back at ground	45°	45°	45°
V Dump angle	45°	45°	45°
Jaw opening width	-	0.7	-

*With quickhitch.

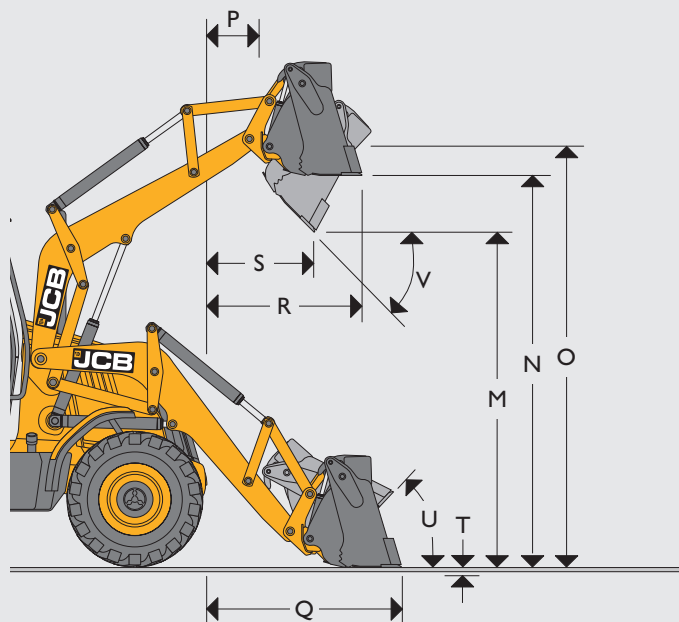

EXCAVATOR DIMENSIONS

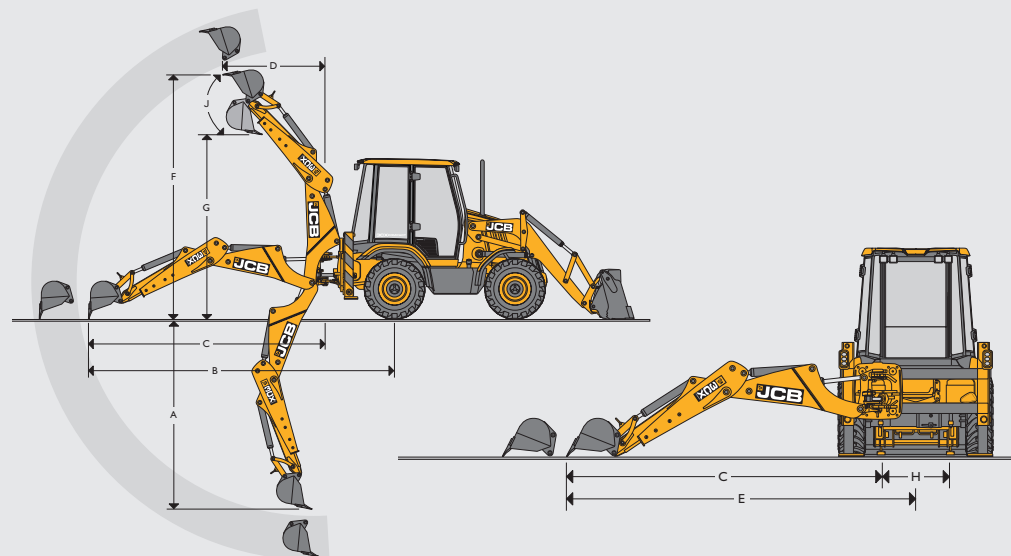

			10ft Standard dipper	10ft Extradig	12ft Standard dipper	12ft Extradig
			m	m	m	m
A	SAE max dig depth	Ext	-	3.75	-	4.36
		Ret	3.07	3.07	3.38	3.38
	SAE 2ft flat bottom	Ext	-	3.72	-	4.27
		Ret	3.05	3.05	3.36	3.36
B	Reach – ground level to rear wheel centre	Ext	-	5.79	-	6.43
		Ret	5.18	5.18	5.82	5.81
C	Reach – ground level to slew centre	Ext	-	4.60	-	5.21
		Ret	3.99	3.99	4.60	4.60
D	Reach – at full height to slew centre	Ext	-	1.92	-	3.17
		Ret	1.44	1.46	2.71	2.71
E	Side reach – to centre line of machine	Ext	-	5.09	-	5.52
		Ret	4.45	4.45	4.91	5.15
F	SAE operating height	Ext	-	4.45	-	4.97
		Ret	4.05	4.05	4.57	4.57
G	Maximum loadover height	Ext	-	3.26	-	3.75
		Ret	2.74	2.71	3.05	3.05
	SAE loadover height	Ext	-	3.20	-	3.69
		Ret	2.47	2.47	3.32	3.29
H	Total kingpost travel	m	1.00	1.00	1.00	1.00
J	Bucket rotation		187°	187°	187°	187°



ONE COMPANY, OVER 300 MACHINES.

Your nearest JCB dealer

BACKHOE LOADER 3CX COMPACT

Gross power: 55kW (74hp) Maximum dig depth: 4.33m Weight: 6070kg

JCB Sales Limited, Rokester, Staffordshire, United Kingdom ST14 5JP

Tel: +44 (0)1889 590312 Email: salesinfo@jcb.com

Download the very latest information on this product range at: www.jcb.com

©2015 JCB Sales. All rights reserved. No part of this publication may be reproduced, stored in a retrieval system, or transmitted in any form or by any other means, electronic, mechanical, photocopying or otherwise, without prior permission from JCB Sales. All references in this publication to operating weights, sizes, capacities and other performance measurements are provided for guidance only and may vary dependant upon the exact specification of machine. They should not therefore be relied upon in relation to suitability for a particular application. Guidance and advice should always be sought from your JCB Dealer. JCB reserves the right to change specifications without notice. Illustrations and specifications shown may include optional equipment and accessories. The JCB logo is a registered trademark of J C Bamford Excavators Ltd.

9999/5922 en-GB 09/19 Issue 4 (T4F)

